

Dear Customer, thank you for purchasing a MASTER S.p.A. product. This guide contains all the information you will need concerning the use of this product. Read the instructions carefully and keep them for further consultation. The receiver module MIR 24 is specially designed for the control of a DC electric motor with mechanical limit switches. All other use beyond the field defined by MASTER S.p.A. is forbidden. This, as well as the breach of the instructions given in this guide, shall release MASTER S.p.A. from any liability and shall annul the product warranty.

**NOTE:** This product is compatible with Arco, Visio, Flute, Kuadro, Kort and equivalent transmitters.

Before starting the programming procedure, read the instruction manual of the transmitter.  
**In the following description the transmitter is represented in a generic way.**

**Package contents**

- ✓ n° 1 MIR 24
- ✓ n° 1 wall bracket
- ✓ this manual

**Disposal**

At the end of the product life cycle, dispose of the device in compliance with local regulations. This product could contain substances that are harmful to human health and the environment: do not dispose of the product in domestic waste.



**Index**

- 01. Warnings
- 02. Electrical connection
- 03. First installation
- 04. Memorization/deletion of radio device
- 05. Operating logic of wind sensor
- 06. Operating logic of sun sensor
- 07. Operating logic of rain sensor
- 08. «Air Change» function
- 09. Orientation function
- 10. Working time
- 11. Buttons logic
- 12. RESET

**Notes on radio systems**

Do not use radio systems in places with strong interference (for example, near police stations, airports, banks, hospitals). It is in any case advisable to carry out a technical inspection prior to installing any radio system in order to identify possible sources of interference. Radio systems can be used where any disturbances or malfunction of the transmitter or receiver do not constitute a risk factor, or if such factor is eliminated using appropriate safety systems. The presence of radio devices working at the same transmission frequency (433.42 MHz) may interfere with the radio receiver and reduce the range of the system, limiting functionality.

**Technical specifications**

- ✓ Power supply: 24 Vdc
  - ✓ Contact capacity: 2A
  - ✓ Dimensions: 45 x 38 x 25 mm
  - ✓ Weight: 40 gr
  - ✓ Operating temperature: from -20 to +55°C
  - ✓ IP protection: IP20
  - ✓ Operating time: adjustable from 5 to 240 sec
  - ✓ Frequency: 433.42 MHz
  - ✓ Memorizable transmitter: 15\*
  - ✓ Memorizable wind sensor: 4
  - ✓ Range (estimates): 100 m outdoor, 20 m indoor
- (\* rain sensor and sun sensor included)

**01. WARNINGS!**

**01A. WARNINGS FOR SAFETY**

- ✓ Incorrect installation can cause serious injuries.
- ✓ Keep these instructions for future maintenance work and disposal of the product.
- ✓ All the product installation, connection, programming and maintenance operations must be carried out only by a qualified and skilled technician, who must comply with laws, provisions, local regulations and the instructions given in this manual.
- ✓ The wiring must comply with current IEC standards.
- ✓ Some applications require hold-to-run operation and can exclude the use of radio controls or require particular safety devices.
- ✓ To prevent potentially dangerous situations, check the operating condition of the roller shutter/awning regularly.

**01B. WARNINGS FOR INSTALLATION**

- ✓ Check that the package is intact and has not been damaged in transit.
- ✓ The product is designed to be inserted inside of junction boxes. The module does not provide any protection against water and only essential protection for contact with solids.
- ✓ It is forbidden to install the module in areas not adequately protected, and near sources of heat.
- ✓ Use momentary (hold-to-run) control buttons. Do NOT use stay-put switches.
- ✓ Position the buttons within sight of the roller shutter/awning but a long way from its moving parts. Position the buttons more than 1.5 m from the floor.
- ✓ Install the product carefully, using suitable tools.
- ✓ If there are several radio appliances in the same system, they must not be less than 1.5 m apart.
- ✓ Do not install the product near metal surfaces.
- ✓ Do not modify or replace parts without the manufacturer's permission. Do not pierce or tamper the box.
- ✓ The antenna cable carries line voltage. Do not cut the antenna cable as this would be dangerous. If the antenna cable is damaged, replace the product.

**01C. WARNINGS FOR USE**

- ✓ The product is not intended for use by persons (including children) with reduced physical, sensory or mental capabilities, or lack of experience and knowledge, unless they are supervised or given instructions on how to use the product by a person responsible for their safety.
- ✓ Before operating the roller shutter/awning, make sure there are no people or objects in the area involved in its movement. Check the automation during movement and keep people at a safe distance, until the movement ends.
- ✓ Do not allow children to play with the appliance or with the fixed control devices. Also, keep the portable control devices (remote controls) out of the reach of children.
- ✓ Do not operate the roller shutter/awning when maintenance operations are being carried out (e.g. window cleaning). If the control device is automatic, disconnect the motor from the power line.

**02. ELECTRICAL CONNECTION**

- ✓ Make the connections with the power switched off.
- ✓ Check that the power line does not come from electrical circuits intended for lighting.
- ✓ A circuit breaker or residual current device must be inserted in the power line. An isolating device with overvoltage category III, namely distance between contacts of at least 3.5 mm, must be inserted in the power line
- ✓ The product has no protection against overloads or short circuits. Install a protective device in the power line that is appropriate for the load, such as a fuse of max. 2 A.
- ✓ You can not connect more than one motor directly to the module.
- ✓ Use momentary (hold-to-run) control buttons. Do NOT use stay-put switches. The control buttons are connected to the line voltage and must therefore be properly isolated and protected.

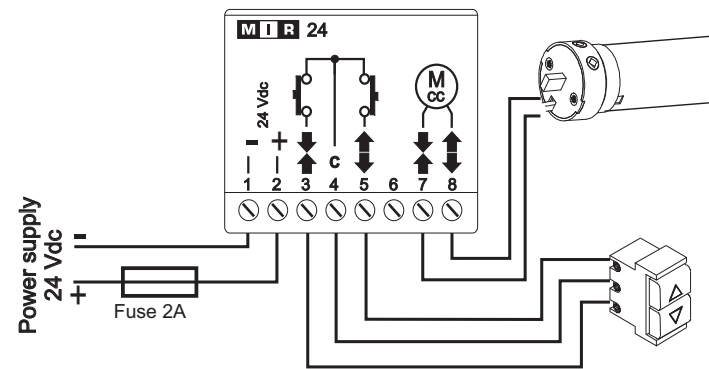

**Power supply**  
The module must be powered at 24Vdc. The supply voltage must be applied to terminals 1 (-) and 2 (+).

**Connecting the motor**  
The motor windings must be connected to the terminals 7 and 8. **You can not connect more than one motor directly to the module.** For each module you can connect only a single DC motor.

**Connecting the command buttons (optional)**  
The buttons must be connected to the terminals 3 and 5, the common thread of the buttons must be connected to terminal 4. You must use **momentary (hold-to-run) control buttons**, do not use buttons with maintained position. More than one command button can be connected to the unit through a parallel connection. To make an up or down movement, press the button for at least 0.5 seconds; to stop the operation briefly press any of the buttons.

**03. FIRST INSTALLATION**

This procedure is used to memorize the first transmitter.

**Warning: before starting the installation procedure, adjust the mechanical limit switches of the motor connected to the module.**

**A**

Supply the module

**B**

The motor makes 4 movements...

IF within 15s press

IF within 15s press

**C**

The motor makes a brief upward movement

In the event that the installation is not successful, you can restore your system to factory condition (see section 12. RESET).

**04. MEMORIZATION / DELETION OF A RADIO DEVICE**

With this procedure you can store / delete others transmitters in addition to the first already stored, or store / delete wind sensor or a sun/wind sensor or store / delete a rain sensor.

**A**

Bring the motor to an intermediate position

**B**

Press for 5 seconds the **PROG** button of a transmitter already memorized.

**C**

The motor makes 2 upward movements

**D** WITHIN 15 SECONDS PRESS:

Hand-held TRANSMITTER	WIND SENSOR	RAIN SENSOR
(1)	(1)	(1)

**E**

MEMORIZED !

DELETED !

The motor signals the operation performed

- ✓ The module can store up to 15 radio codes (excluding sensors, wind or sun / wind radio). The "out of memory" condition is indicated with two downward movements.
- ✓ If the motor has stored a single hand-held transmitter, it can't be deleted (the non-cancellation is indicated by two downward movements).
- ✓ The module can store up to 4 wind radio sensor, one of which may be a sun sensor / wind. The "out of memory" condition is indicated with two downward movements.
- ✓ The module can store more rain sensors.
- ✓ If the sensor is a battery sensor button 1 must be pressed up to 10 seconds.



## 05. OPERATING LOGIC OF WIND SENSOR

If a wind radio sensor measures that the wind speed is above the threshold set on the sensor, the wind sensor sends the message of "wind alarm": the modules tuned to it makes an upward manoeuvre and commands are inhibited as long as it remains the dangerous situation.

### 05.1 TEST RADIO FUNCTION

As soon as in the module is stored a wind sensor is automatically activated control of communication between the wind sensor and the module. If communication is lost for more than 60 minutes, the module performs an upward movement for the protection of the roller. This manoeuvre is performed automatically every 60 minutes until the restoration of radio communication. The factory recommends keeping the "radio test" in order to identify in good time any malfunction of the radio sensor. With the following procedure you can enable or disable the "test radio":

ARCO	FLUTE, KUADRO, KORT	VISIO	Other transmitters...
01. Bring the motor in an intermediate position 02. Press MENU for about 5 sec, until «rS» appears on display 03. Press 1 time PREV / 7 times NEXT. «17» appears on display 04. Press STOP. The motor signals: 1 up = active, 1 down = inactive 05. To deactivate: press PREV To activate: press NEXT 06. Press STOP. The motor signals: 1 up = active, 1 down = inactive	01. Bring the motor in an intermediate position 02. Holding down STOP, press PROG for about 1 sec, until LEDs light 03. Press 1 time UP / 7 times DOWN. 04. Press STOP. The motor signals: 1 up = active, 1 down = inactive 05. To deactivate: press DOWN To activate: press UP 06. Press STOP. The motor signals: 1 up = active, 1 down = inactive	01. Bring the motor in an intermediate position 02. Press MENU, «Menu rx» appears on display 03. Press 1 time PREV / 7 times NEXT. «17» appears on display 04. Press STOP. The motor signals: 1 up = active, 1 down = inactive 05. To deactivate: press DOWN To activate: press UP 06. Press STOP. The motor signals: 1 up = active, 1 down = inactive	See the User manual of the transmitter at section:  «RECEIVER MENU - Function 17 - Test radio»

## 06. OPERATING LOGIC OF SUN SENSOR

If the sun sensor measures a brightness above the threshold set for at least 2.5 minutes, sends the message "sun" and modules, tuned to it, command a downward movement. If the sun sensor measures a brightness below the threshold set for at least 18 minutes, sends the message of "no sun" and modules MIR 24, tuned to it, command an upward movement.

The "sun function" can be activated / deactivated from the transmitter (see transmitter manual under "sun function"). If the "sun function" is deactive, MIR 24 ignores the commands about the sun sent from the radio sensor.

## 07. OPERATING LOGIC OF RAIN SENSOR

If the rain sensor measures a rain intensity exceeds the threshold set on the sensor, the rain sensor sends the message "rain" and modules MIR 24, tuned to it, performs an upward or downward manoeuvre, according to how is set the rain sensor. The manual controls are still active. More rain sensors can be stored in the same MIR 24.

## 08. "AIR CHANGE" FUNCTION

This feature is especially useful if you want to identify a favorite position of the roller blind. Recalling the intermediate limit switch function by a stored portable transmitter, a complete operation of descent is carried out and elapsed the work time, a short upward movement is carried out whose duration can be set via this parameter.

N° of movements	1	2	3	4	5	6	7
<b>AIR CHANGE</b>	inactive	01 sec	02 sec	03 sec	04 sec	05 sec	06 sec

ARCO	FLUTE, KUADRO, KORT	VISIO	Other transmitters...
01. Bring the motor in an intermediate position 02. Press MENU for about 5 sec, until «rS» appears on display 03. Press 8 times NEXT. «08» appears on display 04. Press STOP. The motor signals the current value (1 to 7 movements) 05. Press NEXT the number of times equal to the desired setting (1 to 7) 06. Press STOP. The motor signals the new value (1 to 7 movements)	01. Bring the motor in an intermediate position 02. Holding down STOP, press PROG for about 1 sec, until LEDs light 03. Press 8 times DOWN. 04. Press STOP. The motor signals the current value (1 to 7 movements) 05. Press DOWN the number of times equal to the desired setting (1 to 7) 06. Press STOP. The motor signals the new value (1 to 7 movements)	01. Bring the motor in an intermediate position 02. Press MENU, «Menu rx» appears on display 03. Press 8 times NEXT. «08» appears on display 04. Press STOP. The motor signals the current value (1 to 7 movements) 05. Press UP the number of times equal to the desired setting (1 to 7) 06. Press STOP. The motor signals the new value (1 to 7 movements)	See the User manual of the transmitter at section:  «RECEIVER MENU - Function 08»

- ✓ If you try to set «AIR Change» greater than level 7, the value is rejected and the motor makes 2 short movements down.
- ✓ When «AIR Change» is set on level 1 (inactive), if you command the orientation movements by transmitter or by command buttons, the motor will not move.

## 09. TILTING FUNCTION

This feature can be useful, for example in the handling of sun protection. If the function is activated, the **RIGHT** and **LEFT** function of the transmitters will command short movements which will allow easy orientation of the sun protection. The command can also be given by any buttons connected to the module; to use the function, press a button (less than 0.5 sec), then press it again and hold it until you reach the desired orientation. The factory sets the function to inactive.

N° of movements	1	2	3	4	5
<b>Duration of movement</b>	inactive	slow	>	>>	fast

ARCO	FLUTE, KUADRO, KORT	VISIO	Other transmitters...
01. Bring the motor in an intermediate position 02. Press MENU for about 5 sec, until «rS» appears on display 03. Press 1 time PREV / 2 times NEXT. «12» appears on display 04. Press STOP. The motor signals the current value (1 to 5 movements) 05. Press NEXT the number of times equal to the desired setting (1 to 5) 06. Press STOP. The motor signals the new value (1 to 5 movements)	01. Bring the motor in an intermediate position 02. Holding down STOP, press PROG for about 1 sec, until LEDs light 03. Press 1 time UP / 2 times DOWN. 04. Press STOP. The motor signals the current value (1 to 5 movements) 05. Press DOWN the number of times equal to the desired setting (1 to 5) 06. Press STOP. The motor signals the new value (1 to 5 movements)	01. Bring the motor in an intermediate position 02. Press MENU, «Menu rx» appears on display 03. Press 1 time PREV / 2 times NEXT. «12» appears on display 04. Press STOP. The motor signals the current value (1 to 5 movements) 05. Press UP the number of times equal to the desired setting (1 to 5) 06. Press STOP. The motor signals the new value (1 to 5 movements)	See the User manual of the transmitter at section:  «RECEIVER MENU - Function 12 - Orientation»

- ✓ If you try to set «Orientation time» greater than level 5, the value is rejected and the motor makes 2 short movements down.
- ✓ When «Orientation time» is set on level 1 (inactive), if you command the orientation movements by transmitter or by command buttons, the motor will not move.

## 10. WORKING TIME

Is the closure time of the relays when a manoeuvre is commanded; the working time can be set from 5 to 240 seconds. The factory sets the "working time" to 120 sec.

ARCO	FLUTE, KUADRO, KORT	VISIO	Other transmitters...
01. Bring the motor in an intermediate position 02. Press MENU for about 5 sec, until «rS» appears on display 03. Press 7 times NEXT. «07» appears on display 04. Press STOP. The motor signals the current value (1) 05. Press PREV and NEXT to set a new value(2) 06. Press STOP. The motor signals the new value (1)	01. Bring the motor in an intermediate position 02. Holding down STOP, press PROG for about 1 sec, until LEDs light 03. Press 7 times DOWN. 04. Press STOP. The motor signals the current value (1) 05. Press UP and DOWN to set a new value (3) 06. Press STOP. The motor signals the new value (1)	01. Bring the motor in an intermediate position 02. Press MENU, «Menu rx» appears on display 03. Press 7 times NEXT. «07» appears on display 04. Press STOP. The motor signals the current value (1) 05. Press UP and DOWN to set a new value (3) 06. Press STOP. The motor signals the new value (1)	See the User manual of the transmitter at section:  «RECEIVER MENU - Function 07»

- (1) Example: 1 movement - pause - 5 movements = 15 sec ● Example: 2 movements - pause - 1 movement - pause - 1 long movement = 210 sec  
 (2) Example: 15 sec = press PREV 1 time and NEXT 5 times ● Example: 210 sec = press PREV 21 times  
 (3) Example: 15 sec = press UP 1 time and DOWN 5 times ● Example: 210 sec = press UP 21 times

If you try to set «Working time» lower than 5s or greater than 240s, the value is rejected and the motor makes 2 short movements down

## 11. OPERATION LOGIC OF COMMAND BUTTONS

The buttons can be operated either in PULSE logic or HOLD-TO-RUN logic.

**PULSE:** to activate the motor press a button for at least 0.5 seconds, to stop the motor press briefly (less than 0.5 seconds) one of the two buttons.

**HOLD-TO-RUN:** to activate the motor press a button for at least 0.5 seconds, to stop the motor release the button.

The factory sets the device to work in PULSE logic. To change this setting:

ARCO	FLUTE, KUADRO, KORT	VISIO	Other transmitters...
01. Bring the motor in an intermediate position 02. Press MENU for about 5 sec, until «rS» appears on display 03. Press 1 time PREV / 8 times NEXT. «18» appears on display 04. Press STOP. The motor signals: 1 up = hold-to-run, 1 down = pulse 05. To select PULSE: press PREV To select HOLD-TO-RUN: press NEXT 06. Press STOP. The motor signals: 1 up = hold-to-run, 1 down = pulse	01. Bring the motor in an intermediate position 02. Holding down STOP, press PROG for about 1 sec, until LEDs light 03. Press 1 time UP / 8 times DOWN. 04. Press STOP. The motor signals: 1 up = hold-to-run, 1 down = pulse 05. To select PULSE: press DOWN To select HOLD-TO-RUN: press UP 06. Press STOP. The motor signals: 1 up = hold-to-run, 1 down = pulse	01. Bring the motor in an intermediate position 02. Press MENU, «Menu rx» appears on display 03. Press 1 time PREV / 8 times NEXT. «18» appears on display 04. Press STOP. The motor signals: 1 up = hold-to-run, 1 down = pulse 05. To select PULSE: press DOWN To select HOLD-TO-RUN: press UP 06. Press STOP. The motor signals: 1 up = hold-to-run, 1 down = pulse	See the User manual of the transmitter at section:  «RECEIVER MENU - Function 18 - Buttons logic»

## 12. RESET



This procedure restores the receiver to the default conditions (factory settings). This procedure must only be carried out by qualified technical staff. Having carried out the reset procedure, the qualified technician must promptly carry out all the installation operations described at section 03. FIRST INSTALLATION

### 12A. RESET USING A MEMORIZED TRANSMITTER

- ✓ Select, on the transmitter, the radio channel that controls the device you want to reset.
- ✓ Make sure that this radio channel controls only the device you want to reset.

ARCO	FLUTE, KUADRO, KORT	VISIO	Other transmitters...
01. Bring the motor in an intermediate position. 02. Press MENU for about 5 sec, until «rS» appears on display 03. Press 2 time PREV / 9 times NEXT. «29» appears on display 04. Press STOP. The display flashes, the motor performs some movement 05. Press together PREV and NEXT for about 2 seconds until the motor indicates that the reset was performed (1 moving up / down). 06. Disconnect the power supply and reinstall the motor (see section 3).	01. Bring the motor in an intermediate position. 02. Holding down STOP, press PROG for about 1 sec, until LEDs light 03. Press 2 time UP / 9 times DOWN. 04. Press STOP. The LEDs flash, the motor performs some movement 05. Press together UP and DOWN for about 2 seconds until the motor indicates that the reset was performed (1 moving up / down). 06. Disconnect the power supply and reinstall the motor (see section 3).	01. Bring the motor in an intermediate position. 02. Press MENU, «Menu rx» appears on display 03. Press 2 time PREV / 9 times NEXT. «29» appears on display 04. Press STOP. The display flashes, the motor performs some movement 05. Press together PREV and NEXT for about 2 seconds until the motor indicates that the reset was performed (1 moving up / down). 06. Disconnect the power supply and reinstall the motor (see section 3).	See the User manual of the transmitter at section:  «RECEIVER MENU - Function 29 - Receiver reset»

### 12B. RESET USING THE BUTTON INPUT

- ✓ Switch off power supply to the module
- ✓ Connect as show in figure
- ✓ Switch ON power supply and wait 30 seconds until the motor makes 2 alternating movements, to indicate that factory conditions are restored.
- ✓ Switch off power supply to the module
- ✓ Restore the connections (see section 02. ELECTRICAL CONNECTIONS)
- ✓ Follow the instruction at section 03. FIRST INSTALLATION

